

N° :

Date : 9 avr. 2018

Induction motor

2P LS 56M 0,09kW B3 230VD/400VY 50Hz -

Utilisation : Environment Current ; Ambiance Non corrosive ; Finition - ; Zone Non specific ; General applications ; Ambient temperature -16 +40 °C ; Maximum altitude 1000 m.

Motor characteristics : Aluminium alloy housing ; Aluminium alloy DE endshield ; Aluminium alloy NDE endshield.



Motor definition

Motor definition		Application	General applications
Protection type	-	Main voltage (V)	400
Generation code	-	Connection	DY
Efficiency class	-	Motor winding (V)	230VD/400VY
Number of network phases	3	Rated Frequency (Hz)	50
Number of speed	-	Operation position	IM1001(IMB3)
Polarity	2P	Index of protection	IP55
Motor serie	LS	Index of cooling	IC411
Frame size (mm)	56	Insulation class	F
Lenght code	M	Finish	-
HS rated power (kW)	0.090	Moment of inertia J (kg.m ²)	0.0001500
LS rated power (kW)	-	Motor weight (kg)	3.8
Rated speed (min-1)	2860		
Maximum mechanical speed (min-1)			

Common definitions

Paint shade	RAL6000
Paint system	la (1 polyurethane coat 20/30 microns)

Motor mechanical interface

Mounting flange	-	Shaft material type	Steel shaft
Drive end shaft type	IEC STANDARD shaft end	Nuance of shaft material	-
Diameter DE shaft (mm)	9/6	Second shaft extension	-
Length DE shaft (mm)	20	Diameter NDE shaft (mm)	-
DE bearing mounting	Located	Second shaft end length (mm)	-
DE bearing type	DE ball bearing	NDE bearing type	NDE ball bearing
DE bearing	6201	NDE bearing	6201
Code Type de graissage	Vie		

Motor electrical interface

Connection network type	Terminal box	Cable type	-
Connection network material	Composite materials	Cable gland material	Polyamide cable gland
Connection network position	A	Main cable gland type	1xPE ISO M16
Connection network orientation	up	Principal cable gland position	Right (1)
Connection network relative position	0		

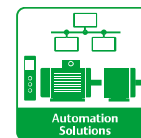
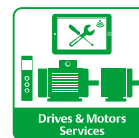
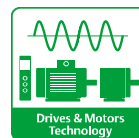

N° :

Date : 9 avr. 2018

Induction motor - 2P LS 56M 0,09kW B3 230VD/400VY 50Hz -

Motor options

Vibration level	A (25µm ; 1.6mm/s ; 2.5m/s ²)	Cover	Plastic cover
Balancing type	Half-key (H)	Drip proof cover option	-
Impregnation type	< 95% ; -16+40°C (T)	cooling type	-
Winding thermal protection	-	Forced ventilation characteristics	-
Space heater	-	Encoder type	-
Draining plugs position	6H	Encoder characteristics	-
Nameplate material	Aluminium nameplate	Screw material	Steel screw
Endshield thermal protection	-	Adaptation for vibration sensor	-
Reinforced winding insulation	-		

Motor characteristics (on mains supply)

Rated speed (min-1)	2860	Unload maximum starting frequency (d/h)	-
Rated current (A)	0.44	Acoustic pressure level (dB(A))	54
No-load current (A)	-	Power factor at 4/4 of the load	0,55
Id / In	5.0	Power factor at 3/4 of the load	0,45
Rated torque (N.m)	0,31	Power factor at 2/4 of the load	0,4
Starting torque (N.m)	1.65	Efficiency at 4/4 (IEC 60 034-2-1) of the load (%)	54.00
Maximum torque (N.m)	1,68	Efficiency at 3/4 (IEC 60 034-2-1) of the load (%)	45.20
Average starting torque (N.m)		Efficiency at 2/4 (IEC 60 034-2-1) of the load (%)	37.10
Rotor locked time (cold) (s)			

N° :

Date : 9 avr. 2018

Induction motor - 2P LS 56M 0,09kW B3 230VD/400VY 50Hz -

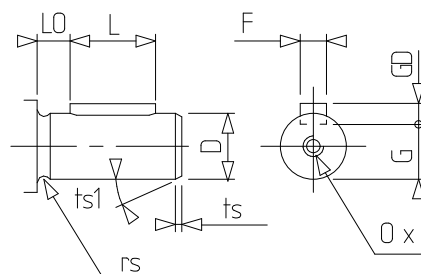
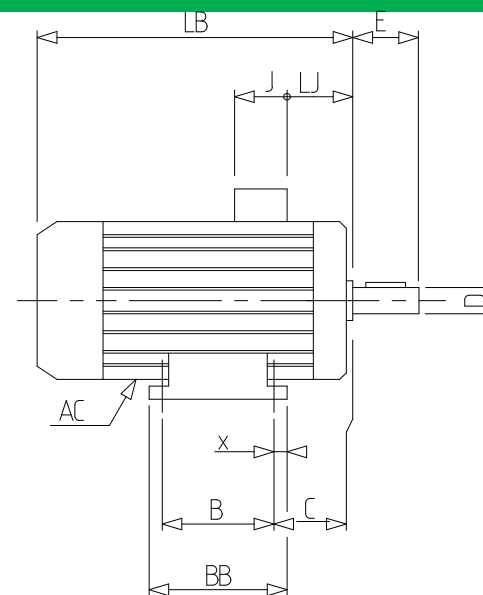
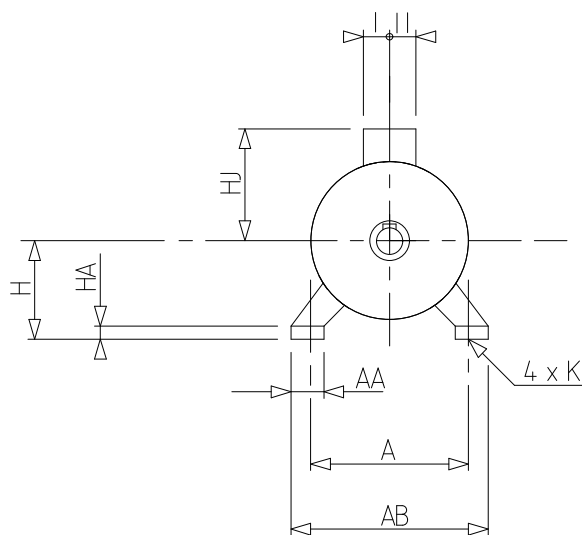

A	90
AA	24
AB	104
AC	110.00
B	71
BB	89
C	36.0
D	9j6
E	20
F	3
G	7
GD	3
H	56
HA	7
HJ	85.0
I	40
II	40
J	80
K	6
L	16
LB	156.0
LJ	17.0
LO	3
O	M4
p	10
x	9.5