

N° :

Date : 4 août 2017

Induction motor

4P LSES 132SM 5,5kW IFT/IE3 380D/400D/415D/690Y-460D 50-60Hz B3 -

Utilisation : Environment Current ; Ambiance Non corrosive ; Finition - ; Zone Non specific ; General applications ; Ambient temperature -16 +40 °C ; Maximum altitude 1000 m.

Motor characteristics : Aluminium alloy housing ; Cast iron DE endshield ; Cast iron NDE endshield.



Motor definition

Motor definition		Application	General applications
Protection type	-	Main voltage (V)	400
Generation code	IFT	Connection	DY
Efficiency class	IE3	Motor winding (V)	380D/400D/415D/690Y-460D
Number of network phases	3	Rated Frequency (Hz)	50-60
Number of speed		Operation position	IM1001(IMB3)
Polarity	4P	Index of protection	IP55
Motor serie	LSES	Index of cooling	IC411
Frame size (mm)	132	Insulation class	F
Length code	SM	Finish	-
HS rated power (kW)	5.500	Moment of inertia J (kg.m ²)	0.0228600
LS rated power (kW)	-	Motor weight (kg)	52.0
Rated speed (min-1)	1462		
Maximum mechanical speed (min-1)	6700		

Common definitions

Paint shade	RAL6000
Paint system	1a (1 polyurethane coat 20/30 microns)

Motor mechanical interface

Mounting flange	-	Shaft material type	Steel shaft
Drive end shaft type	IEC STANDARD shaft end	Nuance of shaft material	-
Diameter DE shaft (mm)	38k6	Second shaft extension	-
Length DE shaft (mm)	80	Diameter NDE shaft (mm)	-
DE bearing mounting	Located	Second shaft end length (mm)	-
DE bearing type	DE ball bearing	NDE bearing type	NDE ball bearing
DE bearing	6308	NDE bearing	6207
Code Type de graissage	Vie		

Motor electrical interface

Connection network type	Terminal box	Cable type	-
Connection network material	Aluminium alloy	Cable gland material	Cable gland not supplied, holes tapped with polyamide plugs
Connection network position	A	Main cable gland type	2xM25 ; With plugs
Connection network orientation	up	Principal cable gland position	Right (1)
Connection network relative position	0		

N° :

Date : 4 août 2017

Induction motor - 4P LSES 132SM 5,5kW IFT/IE3 380D/400D/415D/690Y-460D 50-60Hz B3 -

Motor options

Vibration level	A (25µm ; 1.6mm/s ; 2.5m/s²)	Cover	Metal cover
Balancing type	Half-key (H)	Drip proof cover option	-
Impregnation type	< 95% ; -16+40°C (T)	cooling type	-
Winding thermal protection	-	Forced ventilation characteristics	-
Space heater	-	Encoder type	-
Draining plugs position	6H	Encoder characteristics	-
Nameplate material	Aluminium nameplate	Screw material	Steel screw
Endshield thermal protection	-	Adaptation for vibration sensor	-
Reinforced winding insulation	-		

Motor characteristics (on mains supply)

Main voltage (V)	Rated Frequency (Hz)	HS rated power (kW)	Rated torque (N.m)	Rated speed (min-1)	Rated current (A)	Power factor at 4/4 of the load	Power factor at 3/4 of the load	Power factor at 2/4 of the load	Efficiency at 4/4 (IEC 60 034-2-1) of the load (%)	Efficiency at 3/4 (IEC 60 034-2-1) of the load (%)	Efficiency at 2/4 (IEC 60 034-2-1) of the load (%)
380	50	5.500	35,9	1456.00	10.70	0.87			89.64		
400	50	5.500	35,9	1462	10.3	0.85	0,79	0,68	90.30	91.06	90.76
415	50	5.500	35,9	1466.00	10.20	0.83			90.43		
460	60	-	-	1768.00	9.05	0.83			91.70		

Motor characteristics (on mains supply) 400 V 50 Hz

Starting torque (N.m)	100.52	Id / In	8.55
Average starting torque (N.m)		Id	88.07
Maximum torque (N.m)	129,24	Maximum current (A)	
Unload maximum starting frequency (d/h)	-	No-load current (A)	0.00
Rotor locked time (cold) (s)		Acoustic pressure level (dB(A))	59

Motor characteristics (supplied via drives)

Main voltage (V)	Nominal frequency (Hz)	Temperature rise	Pn (kW)	Nn (min-1)	In (A)	Cos Phi	Mn @ f/10 (N.m)	Mn @ f/5 (N.m)	Mn @ f/3 (N.m)	Mn @ f/2 (N.m)	Mn (N.m)	Mn @ fx1.7 (N.m)	Mn @ fx2 (N.m)
400 D	50	80K	5.5	1462	10.99	0.85	0.00	32.31	32.31	35.90	35.900	20.63	0.00

N° :

Date : 4 août 2017

Induction motor - 4P LSES 132SM 5,5kW IFT/IE3 380D/400D/415D/690Y-460D 50-60Hz B3 -

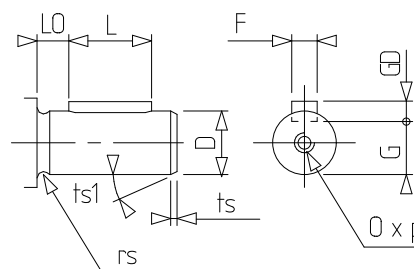
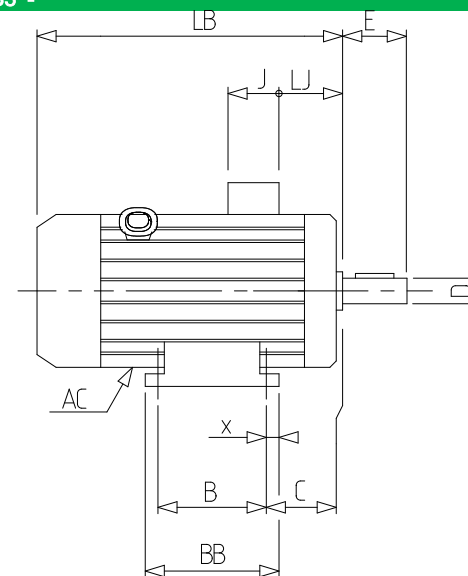
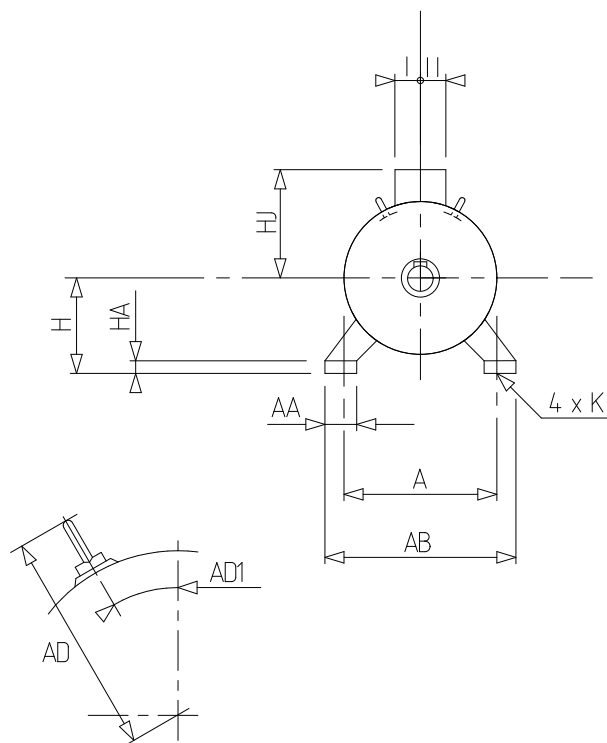

A	216
AA	50
AB	250
AC	272.00
AD1	45
B	140
BB	208
C	89.0
D	38k6
E	80
F	10
G	33
GD	8
H	132
HA	15
HJ	190.0
I	63
II	63
J	126
K	12
L	63
LB	385.0
LJ	17.0
LO	10
O	M12
p	28
rs	0.5
ts	2
ts1	20
x	15