



Manufacturer

Customer

VEM motors GmbH
Carl-Friedrich-Gauß-Straße 1

38855 WERNIGERODE
Deutschland

Three-phase motors with squirrel cage rotor,
Housing grey cast iron

| | | | |
|--------------------------|----------------------|--------------------|-----|
| Type | IE3-W41R 132 MX6 HW | | |
| Design output | (kW) | 5,5 | |
| Design torque | (Nm) | 54 | |
| Class IE | (-) | IE3-88,6% | |
| Efficiency determination | EN 60034-2-1 | | |
| Duty type | | S1 | |
| Design frequency | (Hz) | 50 | |
| Design speed | [rpm] | 970 | |
| Voltage | (V) | 400/690 | |
| Connection | (-) | D | Y |
| Current | (A) | 11.0 | 6.4 |
| Relative pull-in current | (-) | 6 | |
| Relative starting torque | (-) | 2,1 | |
| Relative pull-out torque | (-) | 3 | |
| Efficiency100/75/50 % | (%) | 88,6 / 88,6 / 87,2 | |
| Power factor | (-) | 0,8 | |
| Th. cl. | | 155(F/B) | |
| Coolant temperature | (°C) | -20°C...+40°C | |
| Altitude above sea level | (m) | 1000m | |
| Degree of protection IP | | IP55 | |
| Moment of inertia | (kgm ²) | 0,053 | |
| Motor weight | (kg) | 105 | |
| Bearing, D-side | | 6308 ZZ C3 | |
| Bearing, N-side | | 6308 ZZ C3 | |
| Relubrication interval | (h) | | |
| Grease type | | ASONIC GHY 72 | |
| Grease amount | (g) | | |
| A-sound pressure level | (dB) | 56 | |

Options

| | |
|------------------------------------|--|
| Type of mounting | IM B3 |
| Flange: | - |
| Terminal box | Standard |
| Position of terminal box | on the top |
| Cable gland | Sealing plug |
| Position of cable entry | right |
| Shaft | Standard |
| Bearing | Easy bearing arrangement |
| Special details to bearings | Fixed bearing, N-side |
| Bearing monitoring | none |
| Anti-condensation heating | none |
| Limit values to vibration velocity | Class A |
| | Balancing with half key |
| Colour system | 01 Moderate (KK C2),RAL 7031 blue-grey,70 µm |

Delivery conditions and/or official regulations: IEC / EN 60034-1
Special customer specifications without

This document was produced electronically, all specifications are valid only after confirmation of the manufacturer

Three-phase motors with squirrel cage rotor,
Housing grey cast iron

IE3-W41R 132 MX6 HW

Mounting position

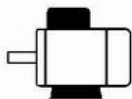

Type of mounting: IM B3
Flange: -
Position of terminal box: on the top
Brake type:
Forced-ventilation:

Terminal box: KK 25 A
Cable gland O: 1 xSealing plug

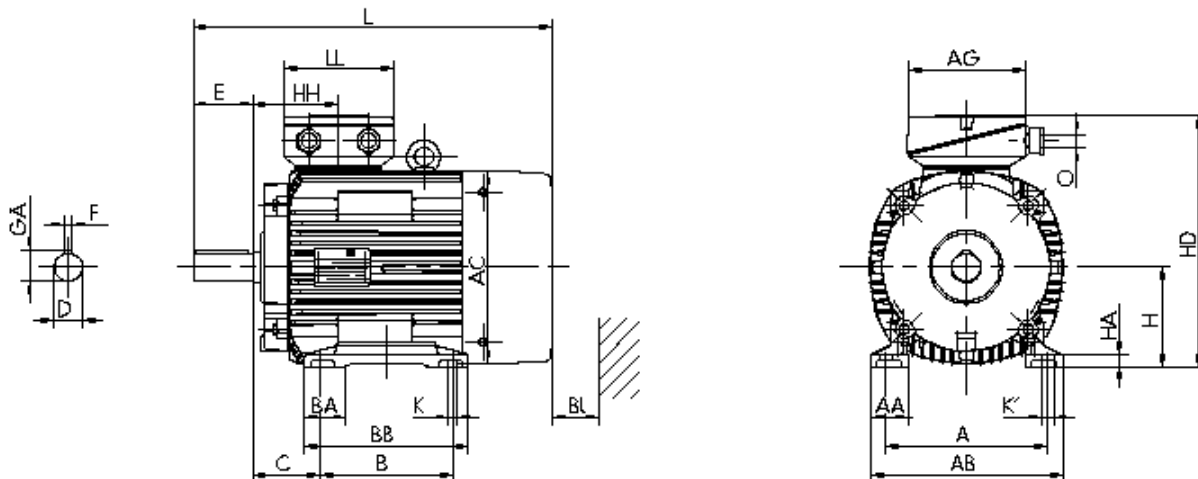

Motor

| | | | | | | | | | | | | | |
|-----|----|-----|-----|----|-----|----|----|-----|-----|----|----|----|----|
| A | AA | AB | AC | AD | B | B' | BA | BA' | BB | C | CA | K | K' |
| 216 | 50 | 256 | 258 | - | 178 | | 53 | - | 218 | 89 | - | 12 | 12 |

Terminal box

| | | | | | | | | | | |
|-----|----|-----|----|-----|-----|----|-----|-----|----|----|
| L | LC | H | HA | HD | HH | BI | AG | LL | BE | AH |
| 579 | - | 132 | 15 | 331 | 114 | 35 | 156 | 145 | - | - |

Flange

| | | | | | |
|---|---|----|---|---|---|
| P | N | LA | M | T | S |
| - | - | - | - | - | - |

Tolerances

| | | | |
|------|----|----|----|
| H | N | D | DA |
| -0,5 | j6 | k6 | k6 |

Shaft-DS

| | | | | |
|----|----|----|----|-----------------|
| D | E | GA | F | DB |
| 38 | 80 | 41 | 10 | DIN 332 DS- M12 |

Shaft-NS

| | | | |
|----|----|----|----|
| DA | EA | GC | FA |
| - | - | - | - |

DB...Centre hole

Delivery conditions and/or official regulations: IEC / EN 60034-1

This document was produced electronically, all specifications are valid only after confirmation of the manufacturer