



Manufacturer

VEM motors GmbH - Werk Zwickau
Äußere Dresdner Str. 35

Customer

akkerstraat 10

08066 ZWICKAU
Deutschland

Three-phase motors with squirrel cage rotor,
Housing grey cast iron

| | | | |
|--------------------------|----------------------|--------------------|-------|
| Type | | IE3-W41R 132 S2T | |
| Design output | (kW) | 5,5 | |
| Design torque | (Nm) | 18,05 | |
| Class IE | [-] | IE3-89,2% | |
| Efficiency determination | | EN 60034-2-1 | |
| Duty type | | S1 | |
| Design frequency | (Hz) | 50 | |
| Design speed | [rpm] | 2910 | |
| Voltage | (V) | 230/400 | |
| Connection | [-] | D | Y |
| Current | [A] | 18.61 | 10.70 |
| Relative pull-in current | [-] | 8 | |
| Relative starting torque | [-] | 2,7 | |
| Relative pull-up torque | [-] | 2,5 | |
| Relative pull-out torque | [-] | 3,6 | |
| Efficiency100/75/50 % | [%] | 89,2 / 90,3 / 89,9 | |
| Power factor | [-] | 0,83 | |
| Th. cl. | | 155(F/B) | |
| Coolant temperature | (°C) | -20...+40 | |
| Altitude above sea level | (m) | 1000 | |
| Degree of protection IP | | IP55 | |
| Moment of inertia | (kgm ²) | 0,0068 | |
| Motor weight | (kg) | 48 | |
| Bearing, D-side | | 6208 2ZN C3 | |
| Bearing, N-side | | 6306 2Z C3 | |
| Grease type | | Asonic GLY 32 | |
| A-sound pressure level | (dB) | a.A. | |

Options

| | |
|--------------------------------------------------|----------------------------------------|
| Type of mounting | IMB5 |
| Flange | FF 265[A 300] |
| Terminal box | Standard |
| Position of terminal box | on the top |
| Cable gland | Sealing plug |
| Position of cable entry | right |
| Shaft | Standard, 1 shaft end |
| Bearing | Easy bearing arrangement |
| Special details to bearings | Fixed bearing, N-side |
| Winding protection | 1 set ptc resistors |
| Limit values to vibration velocity | Class A |
| | Balancing with half key |
| Colour system | 01 Moderate (KK C2),RAL 7031 blue-grey |
| Delivery conditions and/or official regulations: | IEC / EN 60034-1 |

This document was produced electronically, all specifications are valid only after confirmation of the manufacturer

Three-phase motors with squirrel cage rotor,
Housing grey cast iron

IE3-W41R 132 S2T

Mounting position

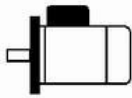

Type of mounting: IMB5
Flange: FF 265[A 300]
Position of terminal box: on the top
Brake type:
Forced-ventilation:

Terminal box: KA 05-13
Cable gland O: 1 xSealing plug

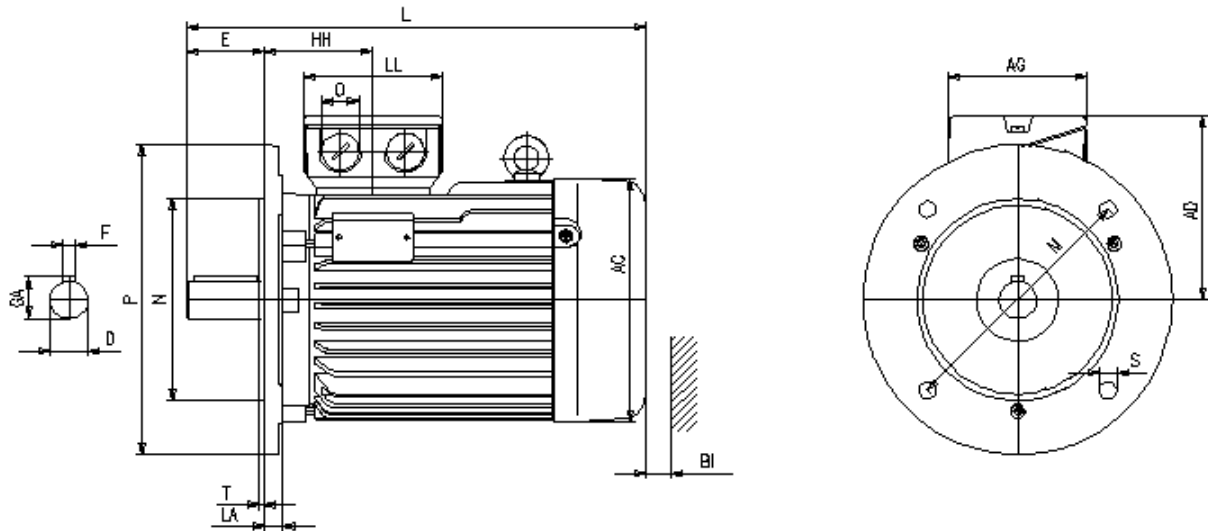

Motor

| | | | | | | | | | | | | | |
|-----|----|-----|-----|-----|-----|----|------------------|-----|-----|----|--------------|---|----|
| A | AA | AB | AC | AD | B | B' | BA | BA' | BB | C | CA | K | K' |
| - | - | - | 196 | 155 | - | - | - | - | - | - | - | - | - |
| L | LC | H | HA | HD | HH | BI | Protection cover | | | | Terminal box | | |
| 460 | - | 132 | - | - | 105 | 20 | L | AG | LL | BE | AH | - | - |
| | | | | | | | | 104 | 112 | - | - | | |

Flange

| | | | | | | | | | |
|-----|-----|----|-----|---|----|------------|----|----|----|
| P | N | LA | M | T | S | Tolerances | | | |
| 300 | 230 | 12 | 265 | 4 | 14 | H | N | D | DA |
| | | | | | | -0,5 | j6 | k6 | k6 |

Shaft-DS

| | | | | |
|----|----|----|----|-----------------|
| D | E | GA | F | DB |
| 38 | 80 | 41 | 10 | DIN 332 DS- M12 |

Shaft-NS

| | | | |
|----|----|----|----|
| DA | EA | GC | FA |
| - | - | - | - |

DB...Centre hole

Delivery conditions and/or official regulations: IEC / EN 60034-1

This document was produced electronically, all specifications are valid only after confirmation of the manufacturer