

N° :

Date : 16 févr. 2018

Induction motor

2P LSES 315SN 110kW IFT/IE3 B3 380D/400D/415D/690Y-460D 50-60Hz -

Utilisation : Environment Current ; Ambiance Non corrosive ; Finition - ; Zone Non specific ; General applications ; Ambient temperature -16 +40 °C ; Maximum altitude 1000 m.

Motor characteristics : Aluminium alloy housing ; Cast iron DE endshield ; Cast iron NDE endshield.



Motor definition

		Application	General applications
Protection type	-	Main voltage (V)	400
Generation code	IFT	Connection	DY
Efficiency class	IE3	Motor winding (V)	380D/400D/415D/690Y-460D
Number of network phases	3	Rated Frequency (Hz)	50-60
Number of speed		Operation position	IM1001(IMB3)
Polarity	2P	Index of protection	IP55
Motor serie	LSES	Index of cooling	IC411
Frame size (mm)	315	Insulation class	F
Length code	SN	Finish	-
HS rated power (kW)	110.000	Moment of inertia J (kg.m ²)	0.5343000
LS rated power (kW)	-	Motor weight (kg)	452.0
Rated speed (min-1)	2968		
Maximum mechanical speed (min-1)	3600		

Common definitions

Paint shade	RAL6000
Paint system	C3_la (1 polyurethane coat 20/30 microns)

Motor mechanical interface

Mounting flange	-	Shaft material type	Steel shaft
Drive end shaft type	IEC STANDARD shaft end	Nuance of shaft material	-
Diameter DE shaft (mm)	65m6	Second shaft extension	-
Length DE shaft (mm)	140	Diameter NDE shaft (mm)	-
DE bearing mounting	Locked	Second shaft end length (mm)	-
DE bearing type	DE ball bearing	NDE bearing type	NDE ball bearing
DE bearing	6316	NDE bearing	6216
Code Type de graissage	Graisseurs		

Motor electrical interface

Connection network type	Terminal box	Cable type	-
Connection network material	Aluminium alloy	Cable gland material	Cable gland not supplied, holes tapped with polyamide plugs
Connection network position	A	Main cable gland type	2xM63 + 1xM16 ; With plugs
Connection network orientation	up	Principal cable gland position	Right (1)
Connection network relative position	0		

N° :

Date : 16 févr. 2018

Induction motor - 2P LSES 315SN 110kW IFT/IE3 B3 380D/400D/415D/690Y-460D 50-60Hz -

Motor options

Vibration level	A (45µm ; 2.8mm/s ; 4.4m/s ²)	Cover	Metal cover
Balancing type	Half-key (H)	Drip proof cover option	-
Impregnation type	< 95% ; -16+40°C (T)	cooling type	-
Winding thermal protection	1xPTC (winding)	Forced ventilation characteristics	-
Space heater	-	Encoder type	-
Draining plugs position	6H	Encoder characteristics	-
Nameplate material	Aluminium nameplate	Screw material	Steel screw
Endshield thermal protection	-	Adaptation for vibration sensor	-
Reinforced winding insulation	-		

Motor characteristics (on mains supply)

Main voltage (V)	Rated Frequency (Hz)	HS rated power (kW)	Rated torque (N.m)	Rated speed (min-1)	Rated current (A)	Power factor at 4/4 of the load	Power factor at 3/4 of the load	Power factor at 2/4 of the load	Efficiency at 4/4 (IEC 60 034-2-1) of the load (%)	Efficiency at 3/4 (IEC 60 034-2-1) of the load (%)	Efficiency at 2/4 (IEC 60 034-2-1) of the load (%)
380	50	110.000	354	2962.00	195.00	0.91			95.20		
400	50	110.000	354	2968	185.0	0.9	0.88	0.84	95.50	95.90	95.83
415	50	110.000	354	2970.00	179.00	0.89			95.64		
460	60	-	-	3574.00	161.00	0.90			95.75		

Motor characteristics (on mains supply) 400 V 50 Hz

Starting torque (N.m)	902.7	Id / In	8.0
Average starting torque (N.m)		Id	1480.00
Maximum torque (N.m)	1097,4	Maximum current (A)	
Unload maximum starting frequency (d/h)	-	No-load current (A)	0.00
Rotor locked time (cold) (s)		Acoustic pressure level (dB(A))	79

Motor characteristics (supplied via drives)

Main voltage (V)	Nominal frequency (Hz)	Pn (kW)	Nn (min-1)	In (A)	Cos Phi	Mn @ f/10 (N.m)	Mn @ f/5 (N.m)	Mn @ f/3 (N.m)	Mn @ f/2 (N.m)	Mn (N.m)	Mn @ fx1.7 (N.m)	Mn @ fx2 (N.m)
400 D	50	110	2968	199	0.9	0.00	300.90	318.60	354.00	354.000	0.00	0.00

N° :

Date : 16 févr. 2018

Induction motor - 2P LSES 315SN 110kW IFT/IE3 B3 380D/400D/415D/690Y-460D 50-60Hz -

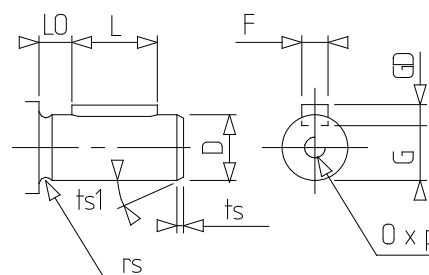
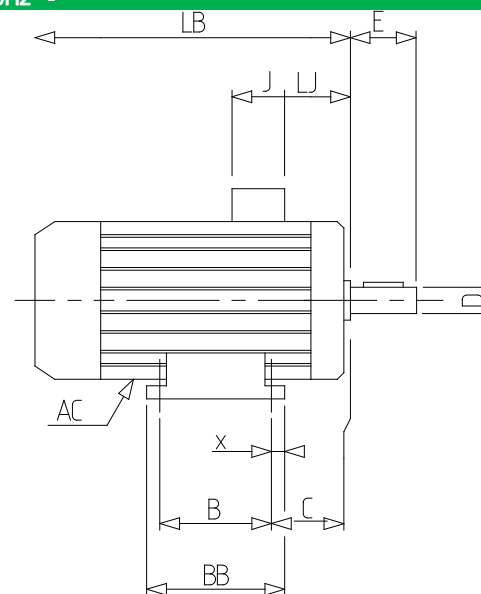
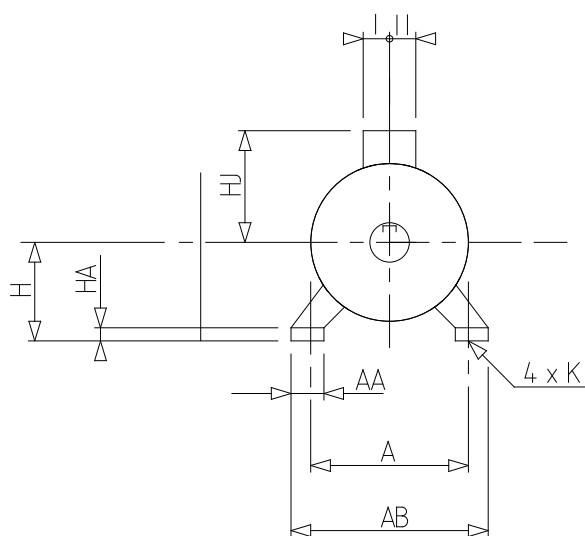

A	508
AA	140
AB	594
AC	479.00
AD1	45
B	406
BB	537
C	216.0
D	65m6
E	140
F	18
G	58
GD	11
H	315
HA	50
HJ	405.0
I	151
II	181
J	292
K	28
L	126
LB	870.0
LJ	68.0
LO	14
O	M20
p	42
rs	0.8
ts	1
ts1	45
x	40